

Comprehensive Explosion Science Course

To include Gas and Dust Explosion Theory
DSEAR & ATEX regulations
Ignition theory, Hazardous Area Classification,
Risk Assessment and Protection Concepts

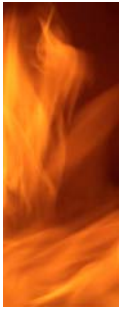

(14 hrs CPD, course accredited by the
Institute of Fire Safety Managers, 7 hrs / day)



Theory
Prevention
Protection
Regulations

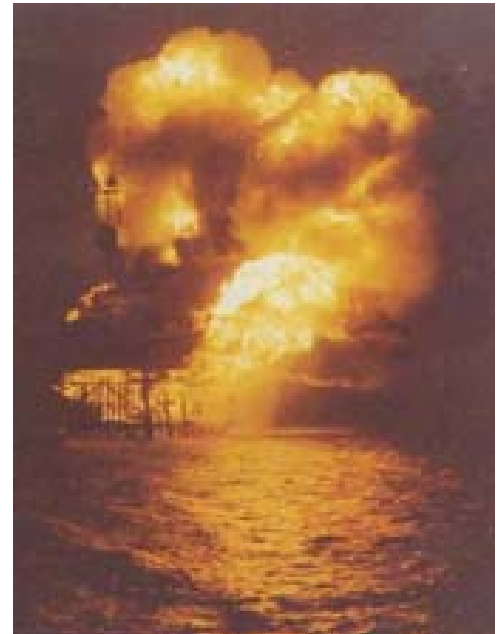

GexCon UK Ltd
West Lancashire Investment Centre
White Moss Park
Skelmersdale
Lancashire
WN8 9TG

Tel: +44 (0) 1695 726565
E: dave.price@gexcon.com
W: www.gexcon.co.uk

Course program

Day 1

- 9.00 Registration & Coffee**
- 9.15 Gas, dust and vapour explosions**
Concepts, combustion, concentration, flame speed, explosion pressure, test methods for dust properties
- 10.30 DSEAR / ATEX user directive (ATEX 1999/92/EC)**
Regulation for safety and health in potentially explosive areas, including requirements for the EPD and preventative measures
- 11.45 Coffee Break**
- 11.55 Video CSB – “Dust Explosions an Insidious Hazard”**
- 12.30 Lunch**
- 13.15 Hazardous area classification for Gas & Dust**
Regulations, methodology, examples, the role of CFD
- 14.45 Explosion effects and consequences**
Pressure, temperatures, radiation, damage to constructions, injuring personnel, gas dispersion and blast prediction using Computational Fluid Dynamics (CFD)
- 15.15 Coffee Break**
- 15.30 Risk analysis**
Methodology, examples of “Short cut semi-quantitative technique”
- 16.30 Examples of gas explosion accidents**
TWA 800, Piper Alpha, Flixborough. Buncefield
- 17.10 End of day 1 summary, questions and answers**
- 17.30 Close**

Course program

Day 2

9.00 Arrival & Coffee

9.15 **ATEX product directive (ATEX 94/9/EC)**
Regulation for equipment and protective equipment

10.00 **Ignition sources – how to prevent explosions**
Electric, electrostatic, mechanical, hot surfaces, housekeeping, inerting, maintenance, grounding, smouldering combustion

11.10 **Coffee Break**

11.20 **Requirements for electric equipment**
Standards In force

11.30 **Requirements for mechanical equipment and protective systems**
Requirements described in equipment standards

12.45 **Lunch**

14.00 **Protection against the consequences of explosions**
Damage to construction, injuring personnel, explosion venting, explosion isolation, explosion suppression. Explosion Containment

15.00 **Coffee Break**

15.10 **Examples of the “good, bad and the ugly”**
Best practice discussion and open session for delegate plant specific enquiries

16.15 **End of course summary, presentation of certificates**

16.30 **Close**

Registration form:

Company:

Delegate name:

Contact Tel:

Contact Email:

Invoice address:

Invoice Email:

2 days

£835 GBP (Excl VAT) , includes all course material and lunches.

10% early bird discount for bookings taken 35 days or more before course commences.

Discount

Further 10% discount for 2 or more employees from the same company or

10% discount for members of IFSM, JOIFF, FABIG, SHAPA & IIRSM.

(Max 20% discount)

Order No

Authorised Name:

Authorised Signature:

Date:

Other comments:

Practical information:

Course date:
(ring required date)

13th – 14th March 2012

22nd – 23rd May 2012

18th – 19th September 2012

4th – 5th December 2012

GexCon UK Ltd

**West Lancashire Investment Centre
Maple View
Whitemoss Park
Skelmersdale
Lancashire
England**

300mtrs from Jnc 4 of the M58



Course
registration:

**Email completed form to: dave.price@gexcon.com
Fax form to: 0844 556 0506
Post form to address above**

Contact person:

Dave Price: +44 (0) 1695 726565

Please note:

In case of cancellation within 1 month of the course 50% of the agreed course fees will be invoiced. Cancellation within 2 weeks of the course 100% of the agreed course fees will be invoiced.



"A unique training course for obtaining a full understanding into the phenomenon of explosions, what effects and consequences can be expected, how to become compliant with the regulations in force whilst delivering a sound basis of safety to protect personnel and equipment as far as reasonably practicable"



The training will benefit those who are responsible for industrial premises that fall under the DSEAR(UK) / ATEX (EU) regulations, engineers who are responsible for designing new process plant and maintaining existing installations and OEM's who are required to design equipment and process according to the ATEX directive.

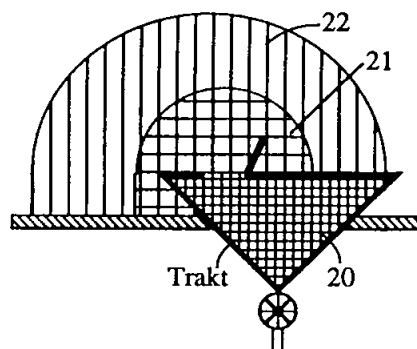



Proposed Presenters (These are liable to change without notice)



Dave Price (Post Graduate Diploma Fire & Explosion Engineering, Leeds University, UK.), Managing Director GexCon UK, has 16 years of experience in the field of gas and dust explosions, until Dec 2007 was working within the Kidde group of companies as an Industrial explosion protection specialist and international sales manager. The main activities in these years have been the design, sale, installation and maintenance of explosion protection and mitigation systems. He has recently established GexCon UK and is responsible for providing UK customers with the wide range of specialist products and services that GexCon are highly respected for. President of the Institute of Fire Safety Managers 2008-2010



Geir H. Pedersen (MSc. Norwegian Institute of Technology (Chemical Engineering)), chief engineer and department manager has 27 years of experience in the field of gas and dust explosions. The main activities in these years have been experimental research, accident investigations, risk analyses and consultancy services. He has given many presentations on gas- and dust explosions.



Kees van Wingerden (MSc, University of Technology Delft, Netherlands, PhD. University of Bergen), marketing director and senior adviser, started his career at TNO (dept. of gas and dust explosions) in the Netherlands. In 1991 he joined CMR/GexCon, in 2002 he became responsible for the sale of explosion protection equipment at INCOM Explosionsschutz, Switzerland and Kidde Brand – und Explosionsschutz, Germany. In 2007 he returned to GexCon. He has more than 31 years of experience in the field (research, testing, consulting, risk analyses). He is convenor of the European Committee CEN/TC 305 WG3 "Devices and systems for explosion prevention and protection".



Barry Pomford (HNC Chemical Engineering, Manchester Polytechnic), Senior risk engineer, started his career at Pilkington Glass as a process engineer, later to become Chief Engineer at Morton International Speciality Chemicals, also many years experience working in the food processing industry for the likes of Arla Foods, and Heinz, UK & Europe. Recently has served with several notified bodies as DSEAR / ATEX Scheme manager. Today he concentrates on risk assessment in relation to ATEX and DSEAR including equipment directive consultancy and testing.